

TERANO 25 IP68

TERANO 25 IP68 is a custom made linear inground luminaire of TERANO series. Crafted with top-quality PU (Polyurethane) materials, guaranteeing exceptional durability and weather resistant seamlessly blends into every surrounding, adding a touch of modern elegance into any space.

- TERANO offers excellent uniformity with colour consistency.
- It is available Opal/Clear with LED strips (Samsung LEDs) or with LED modules (CREE LEDs) with different lenses available.
- TERANO with LED modules are offered with honeycomb to ensure visual comfort.
- Housing material: Stainless steel 316 or anodized aluminium.
- Supplied with in-out IP68 cable & connector as standard (25cm models have only input cable connectors).
- Walk Over: Up to 500kg (5kN).
- Maximum Static Load: Up to 2000kg (20kN) for Opal & Clear models with Honeycomb.
- Ingress Protection: IP68
- IK Rate: IK10

L80/B10 > 50.000h

for models with Samsung LED strips monochromatic, TW

L90/B10 > 50.000h

for models with CREE LED modules

L70/B10 > 50.000h

for RGBW models

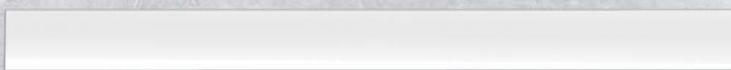
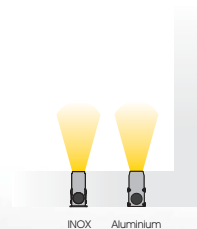



Lighting management options:
On-Off/DALI/0..10V/1..10V/DMX512/PHASE CUT/IR/RF/PUSH BUTTON/Bluetooth

Technical features

Installation:	In-ground
LED light source:	Diffused lighting / Samsung LED. Directional lighting / CREE LED.
Optics:	Monochrome: 2.5°, 5°, 25°, 35°, 15°x40°
Lengths:	25cm, 50cm, 75cm, 100cm, 125cm, 150cm, 175cm, 200cm
No of LEDs (25/50/100/150/200cm):	7/14/28/42/56 (directional)
Power Supply:	24VDC
Power:	Different depending on the model.
Ingress protection:	IP68
Operation Ambient temperature:	-25°C...+50°C

Materials

Main Body:	Natural Anodized anti-corodal aluminium, EN AW-6060 T66
Finishes (End caps):	Anodized anticorodal aluminium EN AW-5052.
Optics:	PMMA collimating lens.
Connectors:	PA66 NYLON
Printed Circuit:	Insulated metal substrate PCB
Power Cards:	15cm, suitable for outdoor use, halogen-free good chemical resistance, cold resistant, UV-resistant, temperature range for fixed installation -50°C to +80°C.
Screws:	Stainless Steel

PU (Polyurethane) material:

Tri- component polyurethane, transparent or translucent for homogeneous light dispersion.

Fully compliance with: REACH, RoHS and ELV European Directives. EC – Directives 89/109 Contact with Food.
Resistance to: Outdoor – Chemicals – Short term water immersion – Hot water. Thermal Shock – Heat – Abrasion
In accordance to: Florida test, Arizona test, Xenotest, QUV-A test. ACID Rain test ASTM G87. TABER test ASTM D 1044. CROCKMETER test ASTM D6279

Stainless Steel 316

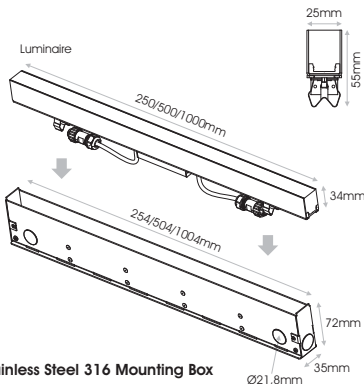
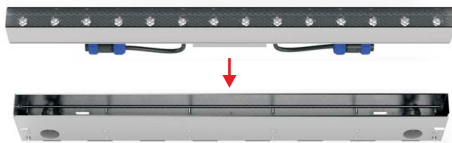

Stainless Steel 316 Mounting Box

- ACR.123 25cm
- ACR.124 50cm
- ACR.125 100cm

Aluminium

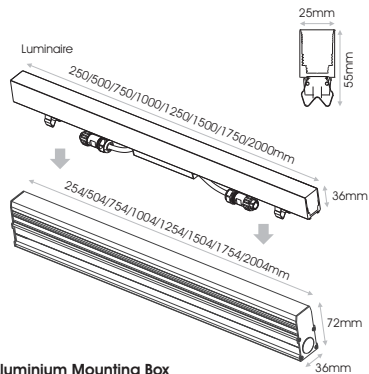
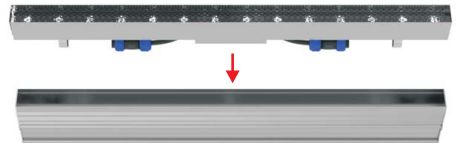

Aluminium Mounting Box

- ACR.115 25cm
- ACR.116 50cm
- ACR.117 75cm
- ACR.118 100cm
- ACR.119 125cm
- ACR.120 150cm
- ACR.121 175cm
- ACR.122 200cm



Model	Luminaire Type	CCT	CRI	15W/m Samsung Led Source	24W/m Cree Led Source	Type / Beam angle	Watt* / Length**	Voltage	Extras	
TERANO 25 IP68 <i>(TERANO 25 68)</i>	Stainless (SS)	2700K	80 (2780)	1840lm	2530lm	With LED strip (Samsung LEDs)				
	Steel 316	2700K	90 (2790)	1554lm	2220lm	Opal (OP)	3.8W / 25cm (04W025)	24VDC (24)	None (0)	
	Anodized (AN)	3000K	80 (3080)	1880lm	2690lm		7.5W / 50cm (08W050)		Honeycomb (1)	
		3000K	90 (3090)	1590lm	2370lm		11.3W / 75cm** (11W075)		Microlouvre (2)	
		4000K	80 (4080)	2000lm	2840lm		15W / 100cm (15W100)			
		4000K	90 (4090)	1670lm	2530lm		18.8W / 125cm** (20W125)			
		5700K	80 (5780)	2045lm	2985lm		22.5W / 150cm** (23W150)			
		5700K	90 (5790)	1710lm	2530lm		26.3W / 175cm** (26W175)			
							With LED modules (CREE LEDs) & Honeycomb			
							Beam Angle***	6W / 25cm (06W025)		Honeycomb*** (1)
							25° (25x)	12W / 50cm (12W050)		Microlouvre*** (2)
							35° (35x)	18W / 75cm** (18W075)		
						15°x40° (1540x)	24W / 100cm (24W100)			
						↓ (XXX)	30W / 125cm** (30W125)			
						↑	36W / 150cm** (36W150)			
						Beam Tilt	42W / 175cm** (42W175)			
						No tilt (0x0)	48W / 200cm** (46W200)			
						2.5° (0x1)				
						5° (0x2)				
						TUNABLE WHITE	20W/m Samsung			
						TW 80 (TW80)	2580lm			
						(WW+CW) 90 (TW90)	2240lm			
						With LED strip (Samsung LEDs)	Opal (OP)	20W / 100cm (20W100)		
						RGBW	19.5W/m			
						RGBW (RGBW)	880lm			
						With LED strip	Opal (OP)	19.5W / 100cm (19W100)		

* Different power consumptions are available upon request.
 ** 75,125,150,175,200cm are available only for anodized model.
 *** Beam angle 25° & 35° only available with Microlouvre.
 Beam angle 15°x40° only available with Honeycomb.

Ordering Code Example: TERANO 25 68-AN-4080-251-24W100-24-2

Accessories



30cm IP68 in line cable connectors for luminaire connections

- 2 pole **WIR.256**
- 3 pole **WIR.257**
- 4 pole **WIR.258**
- 5 pole **WIR.259**

(other cable lengths upon request)



50cm IP68 Power supply cable connector

- 2 pole **WIR.252**
- 3 pole **WIR.253**
- 4 pole **WIR.254**
- 5 pole **WIR.255**

(other cable lengths upon request)



CNC.106
IP68 Junction box 4way / 2-5pole



CNC.109
IP68 Joint connector 2way / 2-5pole



PRH.109
Alligment kit for Stainless steel model



PRH.108
Alligment kit for anodized model



PRH.110
Disassembly kit. Use to take the fixture out of the mounting box.